

ORIGINAL INSTRUCTIONS

FEIDER
MACHINES



BELT SANDER
FPB900W
USER GUIDE

WARNING: READ THESE INSTRUCTIONS BEFORE USE THIS MACHINE.

CONTENTS

1. SAFETY WARNINGS.....	3
2. EXPLANATION OF SYMBOLS.....	7
3. PART LIST.....	8
4. TECHNICAL SPECIFICATION.....	9
5. ASSEMBLY AND USE.....	10
6. SERVICE & MAINTENANCE.....	12
7. DISPOSAL.....	13
8. EC DECLARATION OF CONFORMITY.....	14
9. WARRANTY.....	15
10. PRODUCT FAILURE.....	16
11. WARRANTY EXCLUSIONS.....	17

1. SAFETY WARNINGS

General power tool safety warnings



WARNING Read all safety warnings, instructions, illustrations and specifications provided with this power tool. *Failure to follow all instructions listed below may result in electric shock, fire and/or serious injury.*

Save all warnings and instructions for future reference.

The term "power tool" in the warnings refers to your mains-operated (corded) power tool or battery-operated (cordless) power tool.

1) Work area safety

- a) **Keep work area clean and well lit.** *Cluttered or dark areas invite accidents.*
- b) **Do not operate power tools in explosive atmospheres, such as in the presence of flammable liquids, gases or dust.** *Power tools create sparks which may ignite the dust or fumes.*
- c) **Keep children and bystanders away while operating a power tool.** *Distractions can cause you to lose control.*

2) Electrical safety

- a) **Power tool plugs must match the outlet. Never modify the plug in any way. Do not use any adapter plugs with earthed (grounded) power tools.** *Unmodified plugs and matching outlets will reduce risk of electric shock.*
- b) **Avoid body contact with earthed or grounded surfaces, such as pipes, radiators, ranges and refrigerators.** *There is an increased risk of electric shock if your body is earthed or grounded.*
- c) **Do not expose power tools to rain or wet conditions.** *Water entering a power tool will increase the risk of electric shock.*
- d) **Do not abuse the cord. Never use the cord for carrying, pulling or unplugging the power tool. Keep cord away from heat, oil, sharp edges or moving parts.** *Damaged or entangled cords increase the risk of electric shock.*
- e) **When operating a power tool outdoors, use an extension cord suitable for outdoor use.** *Use of a cord suitable for outdoor use reduces the risk of electric shock.*
- f) **If operating a power tool in a damp location is unavoidable, use a residual current device (RCD) protected supply.** *Use of an RCD reduces the risk of electric shock.*

NOTE The term "residual current device (RCD)" can be replaced by the term "ground fault circuit interrupter (GFCI)" or "earth leakage circuit breaker (ELCB)".

3) Personal safety

- a) **Stay alert, watch what you are doing and use common sense when operating a power tool. Do not use a power tool while you are tired or under the influence of drugs, alcohol or medication.** *A moment of inattention while operating power tools may result in serious personal injury.*
- b) **Use personal protective equipment. Always wear eye protection.** *Protective equipment such as a dust mask, non-skid safety shoes, hard hat or hearing protection used for appropriate conditions will reduce personal injuries.*
- c) **Prevent unintentional starting. Ensure the switch is in the off-position before connecting to power source and/or battery pack, picking up or carrying the tool.** *Carrying power tools with your finger on the switch or energising power tools that have the switch on invites accidents.*
- d) **Remove any adjusting key or wrench before turning the power tool on.** *A wrench or a key left attached to a rotating part of the power tool may result in personal injury.*
- e) **Do not overreach. Keep proper footing and balance at all times.** *This enables better control of the power tool in unexpected situations.*
- f) **Dress properly. Do not wear loose clothing or jewellery. Keep your hair and clothing away from moving parts.** *Loose clothes, jewellery or long hair can be caught in moving parts.*
- g) **If devices are provided for the connection of dust extraction and collection facilities, ensure these are connected and properly used.** *Use of dust collection can reduce dust-related hazards.*
- h) **Do not let familiarity gained from frequent use of tools allow you to become complacent and ignore tool safety principles.** *A careless action can cause severe injury within a fraction of a second.*

4) Power tool use and care

- a) **Do not force the power tool. Use the correct power tool for your application.** *The correct power tool will do the job better and safer at the rate for which it was designed.*
- b) **Do not use the power tool if the switch does not turn it on and off.** *Any power tool that cannot be controlled with the switch is dangerous and must be repaired.*
- c) **Disconnect the plug from the power source and/or remove the battery pack, if detachable, from the power tool before making any adjustments, changing accessories, or storing power tools.** *Such preventive safety measures reduce the risk of starting the power tool accidentally.*
- d) **Store idle power tools out of the reach of children and do not allow persons unfamiliar with the power tool or these instructions to operate the power tool.** *Power tools are dangerous in the hands of untrained users.*
- e) **Maintain power tools and accessories. Check for misalignment or binding of moving parts, breakage of parts and any other condition that may affect the power tool's operation. If damaged, have the power tool repaired before use.**

Many accidents are caused by poorly maintained power tools.

f) **Keep cutting tools sharp and clean.** *Properly maintained cutting tools with sharp cutting edges are less likely to bind and are easier to control.*

g) **Use the power tool, accessories and tool bits etc. in accordance with these instructions, taking into account the working conditions and the work to be performed.** *Use of the power tool for operations different from those intended could result in a hazardous situation.*

h) **Keep handles and grasping surfaces dry, clean and free from oil and grease.** *Slippery handles and grasping surfaces do not allow for safe handling and control of the tool in unexpected situations.*

5) Service

a) **Have your power tool serviced by a qualified repair person using only identical replacement parts.** *This will ensure that the safety of the power tool is maintained.*

Belt sander safety warnings

Hold the power tool by insulated gripping surfaces, because the sanding surface may contact its own cord. *Cutting a "live" wire may make exposed metal parts of the power tool "live" and could give the operator an electric shock.*

WARNING Contact with or inhalation of harmful / toxic dusts arising from sanding painted surfaces, woods and metals can endanger the health of operator and bystanders.







Take special care to guard against these dusts, including the following:

- All persons entering the work area must wear an approved mask specially designed for protection against harmful / toxic dusts, in addition to using the dust extraction facility, and keeping work area well ventilated.
- Children and pregnant women must not enter the work area.
- Do not eat, drink or smoke in the work area.
- Any pre 1960 building may have paint containing lead on wood or metal surfaces. If you suspect workpiece contains lead seek professional advice.
- Some wood and wood type products especially MDF (Medium Density Fibreboard) can produce dust that can be hazardous to your health. We recommend the use of an approved face mask with replaceable filters when using this machine in addition to using the dust extraction facility.

- Hold the machine correctly using two hands and adopt a stable stance, make sure that the mains cable is prevented from coming into contact with the machine or getting caught up on other objects preventing completion of the sanding pass.
- This tool is intended to remove surface material using an abrasive medium.
- Ensure that you have removed foreign objects such as nails and screws from the workpiece before commencing sanding.
- Do not use it for wet sanding, for dry sanding only.
- Where possible, secure smaller workpieces to prevent them from moving under the sander.
- Do not force the sander, let the tool do the work at a reasonable speed. Overloading will occur if too much pressure is applied and the motor slows resulting in inefficient sanding and possible damage to the sander motor.
- Do not use the dust collection box when sanding metal. The hot metal particles could cause residual wood dust or the internal filter paper to catch fire.
- Do not continue to use worn, torn or heavily clogged sanding belts.
- Do not touch the moving sanding belt.
- If the replacement of the supply cord is necessary, this has to be done by the manufacturer or his agent in order to avoid a safety hazard;

2. EXPLANATION OF SYMBOLS

In this manual and/or on the machine the following symbols are may used:

	Read instructions carefully
	In accordance with essential applicable safety standards of European directives
	Class II machine – Double insulation – You don't need any earthed plug.
	Faulty and/or discarded electrical or electronic apparatus have to be collected at the appropriate recycling locations
	Wear eye protection
	Wear hearing protection

3. PART LIST

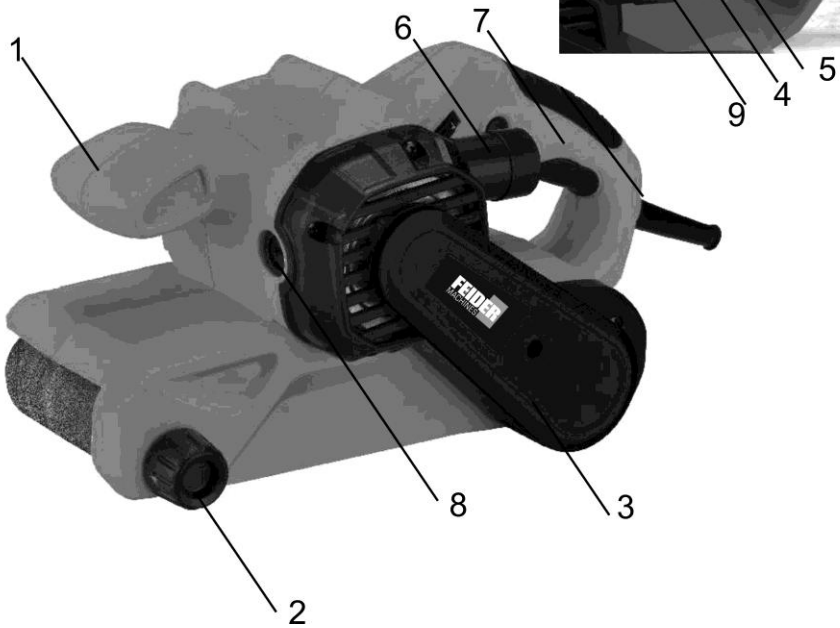

- 1) Front handle
- 2) Belt centralizing knob
- 3) Drive belt cover
- 4) On.off trigger switch
- 5) Lock-on button
- 6) Dust extraction outlet
- 7) Rear handle
- 8) Carbon brush cap
- 9) Speed adjuster

4. Technical specification

Type designation	Belt Sander
Rated voltage	220-240V~ 50Hz
Rated power input	900W
Speed, n ₀	120-340m/min
Sanding belt size	533x 76mm
Level of acoustic pressure L _{pA}	89.0 dB(A), K _{pA} =3dB(A)
Level of acoustic power L _{wA}	100 dB(A), K _{wA} =3dB(A)
Level of vibration a _h	3.41m/s ² K=1.5m/s ²
Protection class	II

Information:

- The declared vibration total value has been measured in accordance with a standard test method and may be used for comparing one tool with another;
- The declared vibration total value may also be used in a preliminary assessment of exposure.

Warning:

- that the vibration emission during actual use of the power tool can differ from the declared total value depending on the ways in which the tool is used; and
- of the need to identify safety measures to protect the operator that are based on an estimation of exposure in the actual conditions of use (taking account of all parts of the operating cycle such as the times when the tool is switched off and when it is running idle in addition to the trigger time).
Wear hearing protection.

5. ASSEMBLY AND USE

Fitting the Dust Collection Bag

This machine is fitted with a dust extraction outlet and collection bag. We recommend that this facility is used at all times, as well as using an approved face mask. Fit the dust collection bag onto the dust extraction outlet.

Use appropriate respiratory protection when sanding some lead painted surfaces, woods and metals so on, which would produce harmful /toxic dusts rising from sanding.

Ventilate your work area adequately when you perform sanding operation.

WARNING! Misuse or failure to follow the safety rules may cause serious personal injury.

Selecting the right grade of sanding belt

Different grades of sanding belt can be purchased from the store where you purchased the tool. Available grades are: Coarse, Medium and Fine.

Use a coarse grit to sand down rough finishes, medium grit to smooth the work and fine grit to finish off.

It is best to make a trial run on a scrap piece of material to determine the optimum grades of sanding belt for a particular job.

GRIT CHART		
Grit	Type	Example of use
60 or less	Very Coarse	Material removal, heavy paint removal, shaping wood
80 – 100	Coarse	Paint removal, rough surface preparation (e.g. non-planed wood)
120 – 150	Medium	Surface preparation planed wood
180 – 220	Fine	Sanding between coats
240 or more	Very Fine	Final finishing

Switching on and off

Connect the plug to the power supply. To start the machine, squeeze the ON/OFF trigger switch; To stop the machine, release the ON/OFF trigger switch.

WARNING! The sander is designed for dry sanding only and under no circumstances should it be used for wet sanding.

Lock-on Button

This machine is fitted with a lock-on button. When the on/off switch is depressed, press lock-on button to get continuous operation without depressing the on/off switch.

Centralizing the sanding belt

Check that the sanding belt is running centrally before using .Centralizing the belt is necessary to stop the belt running off the rollers. Turn the machine with the belt facing the operator. Start the Sander and observe how the sanding belt is running. If the sanding belt is seen to move along the rollers in either direction, it will require centralizing before use.

Turn the centralizing knob either clockwise or anti-clockwise to adjust the belt tracking until the sanding belt is running centrally. Run the Sander for a short time. If the belt is still not running centrally, use the centralizing knob to fine adjust the position of the sanding belt.

Adjust the working speed by turning the knob on the front handle. We recommend using a slow speed initially and then accelerating. The MIN marking is the slowest speed and the MAX marking is the fastest speed.

Sanding

The sander can be used for most sanding operations on materials such as wood, plastic, metal and painted surfaces.

WARNING : Don't use this machine on plaster.



Wear safety goggles and dust mask.

Where possible, secure smaller workpiece to prevent them from moving under the sander. Lower the sander in contact with the workpiece without pressure and then start the sander.

Move the sander slowly over the surface of the workpiece, for best results use the sander in a linear motion not circular. Using the sander in a circular motion may result in the belt tracking slipping. Sand with the grain, in parallel over lapping strokes.

To remove paint or smooth very rough wood, sand across the grain at 45° in two directions, and then finish parallel with the grain. Use the front roller only to sand corners or irregular shapes.

Lift the sander off the work before switching off. Remember to keep your hands away from the moving belt, as it will continue to move for a short time after the machine is switched off.

If there are still scratches on your work after sanding, try either of the following:

-Go back to a coarser grit and sand the marks out before recommencing with the original choice or,

-Try using new sanding belt of the same grit to eliminate the unwanted marks before progressing to a finer grit and finishing the job.

6. SERVICE & MAINTENANCE



Always disconnect the device before performing any adjustment or maintenance operation. **If the supply cord of this power tool is damaged, it must be replaced by a specially prepared supply cord available through the service organization.**

Disconnect from the power supply immediately if the supply cord is damaged. Take care not to expose this tool to the rain.

If the carbon brushes need to be replaced, have this done by a qualified repair person (always replace the two brushes at the same time)

Cleaning

Avoid using solvents when cleaning plastic parts. Most plastic parts are susceptible to damage from various types of commercial solvents and may be damaged by their use. Use clean cloths to remove dirt, carbon dust, etc.

Lubrication

All the bearings in this tool are lubricated with a sufficient amount of high grade lubricant for the life of the unit under normal operating conditions, therefore no further lubrication is required.

CAUTION! Water must never come into contact with the sander.

During use, the carbon brushes will wear down and will be indicated by a possible loss of power and excessive sparking seen through the ventilation slots. When the carbon brushes have worn down to approximately 4-5mm, they will require replacing.

Caution! Make sure that the sander is isolated from the mains power supply before fitting accessories, maintenance and adjustment if in doubt consult a qualified electrician.

Place the sander on a workbench and use a screwdriver to remove the carbon brush cap.

Remove the carbon brush from the brush housing and replace it with a new one. Slide the new carbon brush into the brush housing. Repeat this procedure for the other carbon brush. Then replace the carbon brush housing cover.

Note: carbon brushes must be replaced in pairs.

7. DISPOSAL



CAUTION! This product has been marked with a symbol relating to removing electric and electronic waste. This means that this product shall not be discarded with household waste but that it shall be returned to a collection system which conforms to the European WEEE Directive. Contact your local authorities or ask for advice on recycling. It will then be recycled or dismantled in order to reduce the impact on the environment. Electric and electronic equipment can be hazardous for the environment and for human health since they contain hazardous substances.

8. EC DECLARATION OF CONFORMITY



EC Declaration of conformity
BUILDER SAS
32, rue Aristide Bergès - ZI 31270 Cugnaux – France

Declares that the machine

BELT SANDER
FPB900

Serial number: 20210904945-20210905444

Is in conformity with the European Directives:
Machine Directive 2006/42/EC
EMC Directive 2014/30/EU
RoHS Directive 2011/65/EU+(EU) 2015/863

Noise directive 2000/14/EC +Annex VI & 2005/88/EC

This product is also in conformity with the following standards:

EN 62841-1:2015+AC:15
EN 62841-2-4:2014 AC:15
EN55014-1:2017+A11:2020
EN55014-2:2015
EN61000-3-2:2019
EN61000-3-3:2013+A1:2019

Responsible of the technical file: Mr Olivier Patriarca

Cugnaux, 16/07/2021

A handwritten signature in black ink, appearing to be "Philippe MARIE". The signature is stylized and includes a large, sweeping flourish that extends upwards and to the right.

Philippe MARIE / PDG

9. WARRANTY

The manufacturer guarantees the product against defects in material and workmanship for a period of 2 years from the date of the original purchase. The warranty only applies if the product is for household use. The warranty does not cover breakdowns due to normal wear and tear.

The manufacturer agrees to replace parts identified as defective by the designated distributor. The manufacturer does not accept responsibility for the replacement of the machine, in whole or in part, and/or ensuing damage.

The warranty does not cover breakdowns due to:

- insufficient maintenance.
- abnormal assembly, adjustment or operations of the product.
- parts subject to normal wear and tear.

The warranty does not extend to:

- shipping and packaging costs.
- using the tool for a purpose other than that for which it was designed.
- the use and maintenance of the machine done in a manner not described in the user manual.

Due to our policy of continuous product improvement, we reserve the right to alter or change specifications without notice. Consequently, the product may be different from the information contained therein, but a modification will be undertaken without notice if it is recognized as an improvement of the preceding characteristic.

READ THE MANUAL CAREFULLY BEFORE USING THE MACHINE.

When ordering spare parts, please indicate the part number or code, you can find this in the spare parts list in this manual. Keep the purchase receipt; without it, the warranty is invalid. To help you with your product, we invite you to contact us by phone or via our website:

+33 (0)9.70.75.30.30

<https://services.swap-europe.com/contact>

You must create a "ticket" via the web platform.

Register or create your account.

Indicate the reference of the tool.

Choose the subject of your request.

Describe your problem.

Attach these files: invoice or sales receipt, photo of the identification plate (serial number), photo of the part you need (for example: pins on the transformer plug which are broken).



10. PRODUCT FAILURE

WHAT TO DO IF MY MACHINE BREAKS DOWN?

If you bought your product in a store:

- Empty the fuel tank.
- Make sure that your machine is complete with all accessories supplied, and clean! If this is not the case, the repairer will refuse the machine.
- Go to the store with the complete machine and with the receipt or invoice.

If you bought your product on a website:

- Empty the fuel tank.
- Make sure that your machine is complete with all accessories supplied, and clean! If this is not the case, the repairer will refuse the machine.
- Create a SWAP-Europe service ticket on the site: <https://services.swap-europe.com> When making the request on SWAP-Europe, you must attach the invoice and the photo of the nameplate (serial number).

Contact the repair station to make sure it is available before dropping off the machine.

Go to the repair station with the complete machine packed, accompanied by the purchase invoice and the station support sheet downloadable after the service request is completed on the SWAP-Europe site

For machines with engine failure from manufacturers BRIGGS & STRATTON, HONDA and RATO, please refer to the following instructions.

Repairs will be done by approved engine manufacturers of these manufacturers, see their site:

- <http://www.briggsandstratton.com/eu/fr>
- <http://www.honda-engines-eu.com/fr/service-network-page;jsessionid=5EE8456CF39CD572AA2AEEDFD290CDAE>
- <https://www.rato-europe.com/it/service-network>

Please keep your original packaging to allow for after-sales service returns or pack your machine with a similar cardboard box of the same dimensions.

For any question concerning our after-sales service you can make a request on our website <https://services.swap-europe.com>

Our hotline remains available at +33 (9) 70 75 30 30.



11. WARRANTY EXCLUSIONS

THE WARRANTY DOES NOT COVER:

- Start-up and setting up of the product.
- Damage resulting from normal wear and tear of the product.
- Damage resulting from improper use of the product.
- Damage resulting from assembly or start-up not in accordance with the user manual.
- Breakdowns related to carburetion beyond 90 days and fouling of carburetors.
- Periodic and standard maintenance events.
- Actions of modification and dismantling that directly void the warranty.
- Products whose original authentication marking (brand, serial number) has been degraded, altered or withdrawn.
- Replacement of consumables.
- The use of non-original parts.
- Breakage of parts following impacts or projections.
- Accessories breakdowns.
- Defects and their consequences linked to any external cause.
- Loss of components and loss due to insufficient screwing.
- Cutting components and any damage related to the loosening of parts.
- Overload or overheating.
- Poor power supply quality: faulty voltage, voltage error, etc.
- Damages resulting from the deprivation of enjoyment of the product during the time necessary for repairs and more generally the costs related to the immobilization of the product.
- The costs of a second opinion established by a third party following an estimate by a SWAP-Europe repair station
- The use of a product which would show a defect or a breakage which was not the subject of an immediate report and/or repair with the services of SWAP-Europe.
- Deterioration linked to transport and storage*.
- Launchers beyond 90 days.
- Oil, petrol, grease.
- Damages related to the use of non-compliant fuels or lubricants.

* In accordance with transport legislation, damage related to transport must be declared to carriers within 48 hours maximum after observation by registered letter with acknowledgement of receipt.

This document is a supplement to your notice, a non-exhaustive list.

Attention: all orders must be checked in the presence of the delivery person. In case of refusal by the delivery person, it you must simply refuse the delivery and notify your refusal.

Reminder: the reserves do not exclude the notification by registered letter with acknowledgement within 72 hours.

Information:

Thermal devices must be wintered each season (service available on the SWAP-Europe site). Batteries must be charged before being stored.



BUILDER SAS
32, rue Aristide Bergès - ZI 31270 Cugnaux – France
Made in PRC 2021